

KISAE

Abso Sinewave Inverter-Charger 3000W (IC1230150)

Owner's Manual



For safe and optimum performance, the KISAE *Abso Inverter-Charger 3000* must be used properly. Carefully read and follow all instructions and guidelines in this manual and give special attention to the **CAUTION** and **WARNING** statements.

PLEASE KEEP THIS MANUAL FOR FUTURE REFERENCE

Disclaimer

While every precaution has been taken to ensure the accuracy of the contents of this guide, **KISAE Technology** assumes no responsibility for errors or omissions. Note as well that specifications and product functionality may change without notice.

Important

Please be sure to read and save the entire manual before using your **KISAE Inverter-Charger**. Misuse may result in damage to the unit and/or cause harm or serious injury. Read manual in its entirety before using the unit and save manual for future reference.

Product Numbers

IC1230150 *Abso Inverter-Charger 3000*

Document Part Number

MU IC1230 Rev A

Service Contact Information

Email: info@kisaetechnology.com

Phone : 1 604 320-7857

Web : www.kisaetechnology.com

IMPORTANT SAFETY INFORMATION

This section contains important safety information for the unit. Each time, before using the unit, READ ALL instructions and cautionary markings on or provided with the unit, and all appropriate sections of this guide.

The unit contains no user-serviceable parts. See Warranty section for how to handle product issues.

DANGER: Fire and/or Chemical Burn Hazard. Failure to follow these instructions can result in death or serious injury!

- Do not cover or obstruct any air vent openings and/or install in a zero-clearance compartment.
- When working with electrical equipment or lead acid batteries, have someone nearby in case of an emergency.
- Study and follow all the battery manufacturer's specific precautions when installing, using and servicing the battery connected to the inverter.
- Wear eye protection and gloves.
- Avoid touching your eyes while using this unit.
- Keep fresh water and soap on hand in the event battery acid comes in contact with eyes. If this occurs, cleanse right away with soap and water for a minimum of 15 minutes and seek medical attention.
- Batteries produce explosive gases. **DO NOT** smoke or have an open spark or fire near the system.
- Keep unit away from moist or damp areas.
- Avoid dropping any metal tool or object on the battery. Doing so could create a spark or short circuit which goes through the battery or another electrical tool that may create an explosion.

DANGER: Shock Hazard. Keep away from children!

- Avoid moisture. Never expose unit to snow, water etc.
- Unit provides 120 VAC, treat the AC output the same as regular wall AC sockets at home.

DANGER: Explosion hazard!

- DO NOT use the unit in the vicinity of flammable fumes or gases (such as propane tanks or large engines).
- AVOID covering the ventilation openings. Always operate unit in an open area.
- Prolonged contact to high heat or freezing temperatures will decrease the working life of the unit.

FCC INFORMATION

This equipment has been tested and found to comply with the limits for a Class B digital device, pursuant to part 15 of the FCC Rules. These limits are designed to provide reasonable protection against harmful interference in a residential installation. This equipment generate, uses and can radiate radio frequency energy and, if not installed and used in accordance with the instructions, may cause harmful interference to radio communications. However, there is no guarantee that interference will not occur in a particular installation. If this equipment does cause harmful interference to radio or television reception, which can be determined by turning the equipment off and on, the user is encouraged to try to correct the interference by one or more of the following measures:

- Reorient or relocate the receiving antenna.
- Increase the separation between the equipment and the receiver.
- Connect the equipment into an outlet on a circuit different from that to which the receiver is connected.
- Consult the dealer or an experienced radio/TV technician for help.

LIMITATIONS ON USE

Do not use in connection with life support systems or other medical equipment or devices.

Table of Contents

| | | |
|----|---------------------------|----|
| 1. | INTRODUCTION..... | 5 |
| 2. | PRODUCT DESCRIPTION | 5 |
| 3. | INSTALLATION | 6 |
| 4. | UNIT OPERATION..... | 10 |
| 5. | FEATURE SETTING..... | 13 |
| 6. | TROUBLESHOOTING | 14 |
| 7. | SPECIFICATIONS | 15 |
| 8. | WARRANTY..... | 16 |

1. INTRODUCTION

Thank you for purchasing the KISAE **Abso Inverter-Charger**. With our state of the art, easy to use design, this product will offer you reliable service by providing AC power for your home, cabin, boat, RV or Trailer and recharge your battery automatically when utility AC is available. The sinewave output inverter can run many AC-powered appliances when you need AC power anywhere. The multi-stage battery charger will charge different types of batteries. The transfer switch will automatically switch the load to the battery power when the utility power is interrupted.

Feature Highlights

- The inverter provides true sinewave output power for your microwave, entertainment system, computer and other loads. The AC output power is identical to the AC power provided by the utility grid. It can handle sensitive loads such as dimmer switches and appliances with speed controls.
- High surge power to start difficult load like sump pumps, refrigerators, or A/C compressors.
- The battery charger has high output, multi-stage charging capability to minimize charging time. The Power Factor Corrected (PFC) input minimizes AC input current required for charging.
- Optional Battery Temperature Sensor (BTS) is available and used to sense the battery temperature to correct charging voltage to ensure the battery is fully charged.
- A Manual Equalization Mode is built-in to improve the life and performance of flooded batteries.
- The charger can charge dead batteries as low as 3 volts.
- During utility mode, the built-in AC load sensing circuit will automatically reduce charging current if there is a high demand on AC load. This avoids the tripping of the shore circuit breaker.

2. PRODUCT DESCRIPTION

The KISAE Abso Inverter-Charger includes the items list below.

- Inverter-Charger base unit
- Remote Display
- 25 ft (7.6 m) remote display cable
- Owner's manual (P/N: MU IC1230)

Understanding the unit features

Front Panel



AC Wiring Compartment

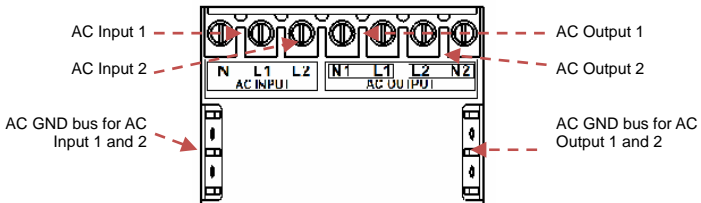

Control Panel

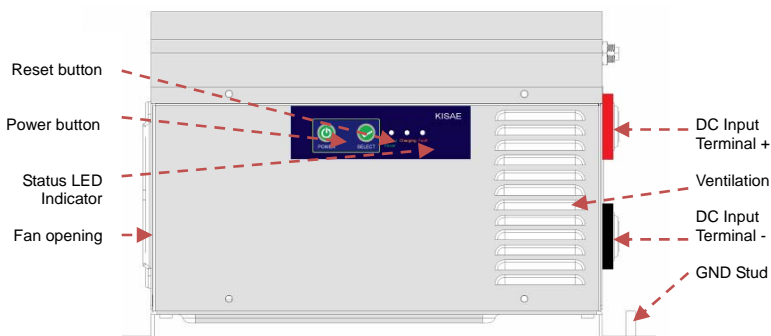

3. INSTALLATION

DANGER: All wiring should be done by a certified technician or electrician to ensure adherence to the applicable electrical safety wiring regulations and installation codes. Failure to follow these instructions can damage the unit and could also result in personal injury or loss of life.

CAUTION: Before beginning unit installation, please consider the following:

- The unit should be used or stored in an indoor area away from direct sunlight, heat, moisture or conductive contaminants.
- When placing the unit, allow a minimum of three inches of space around the unit for optimal ventilation.

Preparing for Installation

Before you begin the installation, be sure to review the Important Safety Instruction on page 3 of this manual and be aware of all safety and electrical codes which must be met in your area. AC Input of the inverter charger can be supplied from either a split-phase or a dual-input AC Source. See below to understand more about the unit before you start your installation.

Input AC Source from Split-Phase:

The split-phase AC source has 2 lines, 1 neutral and 1 ground. The two 120Vac lines are 180 degree out of phase with each other with a total of 240Vac when measured from line to line. The voltage between each line to neutral is 120Vac.

Input AC Source from Dual Input:

The dual input has 2 line inputs, 1 neutral and 1 ground. The two 120Vac lines are in phase and must come from the same source.

AC Loads:

In Battery-Inverter mode, the unit's AC Output L1 and L2 lines are connected together to provide 120Vac on both lines.

In Pass-Through mode, the AC source connected to the unit's AC input is passed through to the AC Output (load).

DANGER: Electrical Shock Hazard. Do not connect 240VAC load to the AC Output of the unit.

AC Output Neutral Bonding:

Each AC source must have its neutral conductor bonded to ground.

When the KISAE Inverter-Charger is running in Battery-Inverter mode, the internal neutral-to-ground bonding system is enabled. The unit will act as an AC source and will automatically connect the AC Output Neutral (N1 & N2) circuit to safety ground.

When the unit is running in Pass-Through mode, the internal neutral-to-ground bonding system is disabled. The unit will not act as an AC source and the AC Output (N1 & N2) to safety ground is disconnected inside the unit. Therefore, the AC Input source that is connected to the Inverter-Charger should have its own neutral-to-ground connection. If not, have an electrician look into bonding the AC source's neutral to ground at your AC source.

Typical Wiring block diagram of the Inverter-Charger

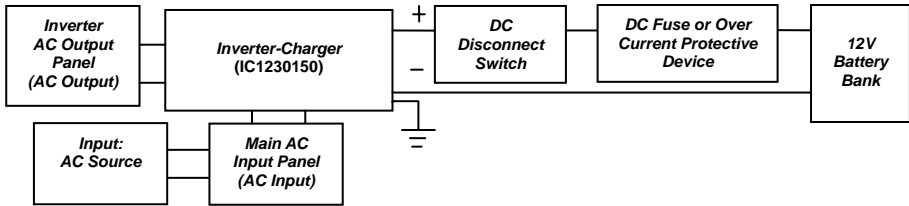

12V Battery Bank:

- The use of a deep cycle battery is highly recommended for power inverter application.
- For battery size, you need to identify what you wish to operate, and for how long. KISAE recommends that you purchase as much battery capacity as possible. See more on Estimated Run Times in Section 4.

DC Cable:

- All DC cables used require multi-strand insulated cable.
- The DC cables must be copper and must be rated 105°C minimum.
- Based on National Electrical Code, cable size of 4/0 AWG is required for cable length < 5 ft. Use of smaller gauge cable or longer cable length may cause the inverter to shutdown under heavy load and may also melt the cable insulation and catch fire and can result in death or serious injury.

DC Grounding:

- The chassis of the unit has to be grounded properly.
- For Marine application, the DC grounding cable size may be one size smaller than the minimum size conductor required for the DC current carrying conductors, providing the overcurrent protection device in the DC positive conductor is rated no greater than 135% of the capacity of the DC grounding conductor, and the conductor is no smaller than #16AWG.
- For Recreational Vehicle application, the unit has to be grounded to the vehicle chassis with a minimum #8 AWG copper conductor with either green insulator or bare wire.

Important: The unit is grounded through the ground stud of the unit .

DC Fuse or Over Current Protective Device:

- A DC-rated fuse or a DC-rated over-current protective device connected along the DC positive line is required.
- Based on the National Electrical Code requirement, a fuse or circuit breaker with a minimum of 350 Adc is required.
- Based on the size of your 12V Battery Bank, determine the overall short circuit current rating of the battery bank from the battery manufacturer. The fuse or circuit breaker chosen must be able to withstand the short circuit current that may be generated by the battery bank.
- For Marine application, the over current protective device needs to be installed within 7 inches (17.8cm) from the battery positive terminals.

DC Disconnect Switch:

- Select a DC Disconnect Switch with the same or higher rating of the selected fuse or over current protective device.
- The DC Disconnect Switch is used to disconnect the DC power between the unit and the battery bank during service, maintenance or trouble shooting.

Main AC Input Panel (wire size and breaker size):

- For Dual AC Input, #6 AWG AC Input wire is required.
- For Split Phase AC Input, #10 AWG AC Input Wire is required for all the AC connections between the AC source and the AC Input port.
- To meet CSA, UL and electrical code requirements and to protect system wiring, the AC input line must be provided with an overcurrent protection device for which a 30A branch circuit breaker is required to connect each AC Line to the unit's AC Input.

Important: Follow the electrical and/or building code when you connect the unit to any AC source.

Inverter AC Output Panel (wire size and breaker size):

- #10 AWG wire is required for all AC Output connections based on the full 30A pass-through rating between the unit and the AC Inverter AC Panel.
- To meet CSA, UL and electrical code requirements and to protect system wiring, the AC input line must be provided with an overcurrent protection device for which a maximum 30A branch circuit breaker is required to connect each AC Output Line to the unit's AC Output. If an AC Output wire of smaller than #10 AWG is used, then the overcurrent protection device will have to be smaller. Follow the electrical and/or building code to choose your protection device rating.

Installing the Inverter-Charger System

WARNING: Electrical Shock Hazard

The unit 'On/Off' switch does not disconnect the DC power from the battery. Use the DC Disconnect Switch or disconnect the DC input cable connection to disconnect the DC power from the battery before working on any circuits connected to the unit. Use the AC circuit breaker to disconnect any AC power to the unit before servicing. Failure to follow these instructions can result in death or serious injury.

Installation:

- Choose an appropriate mounting location. The unit should be installed away from the battery in a separate well ventilated compartment. Do not install the unit in any compartment containing flammable gases or liquids like gasoline or in the battery compartment where they may be explosive hydrogen gas from the batteries present.
- The length and size of the DC cables will affect unit performance.
- For indoor use, the unit can be mounted in any direction except with the fan panel (panel with fan opening) facing upwards or downwards.
- The location to install the unit has to have a normal air temperature between 0°C – 60°C (32°F-140°F). The cooler the better, or overheating may result.
- Use the mounting template below to mark the positions of the mounting screws.
- Drill the 4 mounting holes and place the Inverter-Charger in position and fasten the unit to the mounting surface.

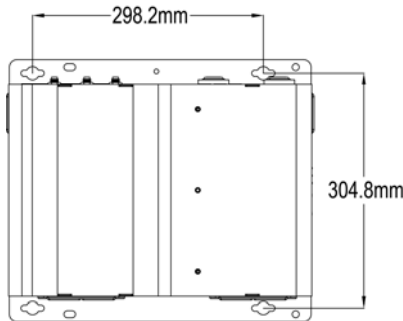

AC Input Wire Connection:

DANGER: Make sure all the AC wiring being connected to the unit is physically disconnected or by opening the circuit breaker from the electrical sources. All wiring must be done in accordance with local and national electrical wiring codes.

CAUTION: The terminal block is split into AC Input and AC Output sections. Damage will occur to unit if it is wired incorrectly.

- The AC and DC wire cannot be mixed together in the same conduit.
- The AC input and AC Output wire should be separated out through the two AC knockouts located at the bottom of the unit.
- Remove AC compartment cover by unscrewing the four screws located on the four corners of the AC compartment cover.
- There are two ground bus locations inside the AC Wiring Compartment. The ground bus

located at the left hand side of the AC compartment is intended for use with AC Input ground wire. The right hand side ground bus is intended for use with AC Output ground wire.

- Remove the left hand side AC knockout. Install the strain-relief clamp in the AC knockout.
- Run the AC input wire through the strain relief clamp.
- Connect AC Input wire Line 1 to L1, Neutral to N and Line 2 to L2 of the terminals and Ground to ground bus.
- Secure the strain-relief clamp.

AC Output Wire Connection:

- Similar procedure as connecting the AC Input wire: remove the right hand side AC knockout. Install the strain-relief clamp in the AC knockout.
- Run the AC output wire through the strain relief clamp.
- For Line for Dual Output, connect AC output wire Line 1 to L1, Neutral 1 to N1 and Line 2 to L2, Neutral 2 to N2 of the terminals and Ground to the ground bus.
- Secure the strain relief clamp.
- Place the AC compartment cover and secure with the four screws.

Unit Chassis Grounding Connection:

DANGER: The unit chassis has to be grounded properly. Never operate the Inverter-Charger without proper grounding. Failure to do so may result in death or serious injury.

- Connect the grounding cable's ring terminal to the unit ground screw.
- Connect the other side of the cable to the common grounding point.

DC Input Connection:

CAUTION: Reversing the DC Input terminal will damage the unit and it cannot be repaired. Damage caused by reverse polarity connection is not covered by the warranty.

- Connect one end of the negative DC input cable to the Inverter-Charger DC negative terminal. Connect the other end of the negative DC input cable to the battery negative terminal.
- Make sure the DC Disconnect Switch is in the OFF position.
- Connect one end of the positive DC input cable to the Inverter-Charger DC positive terminal. Connect the other end of the positive DC input cable to one of the terminals of the DC Disconnect Switch.
- Connect a DC input cable between the other terminal of the DC Disconnect Switch and one side of the terminal of the fuse holder.
- Connect a DC input cable between the other terminal of the fuse holder and the battery positive terminal.
- Install the selected fuse to the fuse holder.
- Turn DC Disconnect Switch to ON position.

Remote Display Connection:

- Install the RJ45 standard cable to your desired location. Please note polarity.
- Connect one end of the RJ45 cable to one of the two Remote 1 or 2 port on the unit and the other end of the cable to the Display Panel. Please note the polarity.

Optional Battery Temperature Sensor Connection:

- Insert the RJ45 plug from the battery temperature sensor to the Inverter-Charger's Battery Temperature Sensor port. Please note the polarity
- Select the battery for which you would like to monitor the temperature, connect the Battery Temperature Sensor to the negative terminals of this battery.

Test the Installation:

- Switch DC disconnect switch and all AC circuit breaker to ON to provide DC power to the unit.
- The status LED display will turn on. If AC input source is available, 'Charging' green LED turns On. This indicates the unit is running in by-pass mode meaning AC output is running from the AC input source.
- Disconnecting the AC input source by turning OFF the 30A branch breaker. 'Battery Power' green LED will turn On. This indicates the unit is running in battery power mode.
- Plug in a small AC load like a 40W table lamp or small appliance to the AC socket to verify AC is available.

- The unit is successfully installed and functioning properly.

4. UNIT OPERATION

Auto Backup Mode (Factory Default Setting)

The unit is fully automatic. When utility power is available, the unit is running in AC bypass mode. AC output is supplied from the utility. The internal AC charger is ON and will automatically top up the battery bank that is connected to the unit. When there is a power failure from the utility or an AC source is not available, the unit will run on battery power and the unit will generate sinewave AC output to maintain and operate the load continuously.

| Factory Default Setting | |
|-------------------------------|-----------|
| Charger | On |
| Inverter | On |
| SCR set | 30A |
| Power Save | Off |
| Battery Type | AGM |
| Set Current | 150A |
| EQ Mode | Off |
| Fault Alarm | On |
| Display Background Brightness | 80% |
| Background Light Timer | 3 minutes |

Non-Backup Mode

Same as Auto Backup Mode but when there is a power failure of the utility or the AC input source is not available, the inverter will not turn ON automatically. You are required to manually turn ON the inverter. This setting is the same as factory default but with Inverter set to OFF.

Understanding the Display Functions



LED Indicator functions on unit display and remote display:

| Status | Display | Function/Status |
|---------------|----------------------|--|
| Battery Power | Green LED ON (solid) | Battery Power Mode. Remote LCD Display shows: - Battery DC Voltage and Current - Inverter AC Output Voltage and Current e.g. DC: 12.5V 30A AC: 120V 2.7A Press '+' or '-' key to check AC Output Power. e.g. System Power 0.33 KW |
| Charging | Green LED ON (solid) | Pass-Through Mode. Battery is fully charged. Remote LCD Display shows: - AC Input Voltage and Current - Battery DC Voltage and charging current e.g. AC: 120V 15A DC: 12.0V 5A Press '+' or '-' key to check charging stage. e.g. Charge Stage Float Press '+' or '-' key to check AC Input Power. e.g. System Power 1.80 KW |

| | | |
|-------|-------------------------|--|
| | Green LED ON (flashing) | Pass-Through Mode (AC mode). Battery Charging is in progress. Remote LCD Display shows: - Battery DC Voltage and charging current - AC Input Voltage and Current e.g. AC: 120V 20A DC: 12.0V 50A Press '+' or '-' key to check charging stage. e.g. Charge Stage ABS Press '+' or '-' key to check AC Input Power. e.g. System Power 2.4 KW |
| Fault | Red ON (solid) | Unit has shutdown. Display shows error code and error message. - Low battery shutdown e.g. FAULT: E01 Low Battery |

Push Button Functions on Unit

A beeping sound will occur every time that any button on the unit is triggered.

| Button | Function |
|---------------|--|
| Power | Turns unit On/Off. Press and hold for 1 second to turn unit On/Off |
| Reset | Reset the unit: Press once to reset the unit. This may be required when an error is detected on the unit |

Push Button Functions on Remote Display

A beeping sound will occur every time any button on the unit is triggered.

| Button | Function |
|---------------|--|
| O | Turns LCD display On/Off. Press and hold for 2 seconds to turn display On/Off. Display shows unit model number and revision. e.g. Inverter/Charger 3000W REV 1.1 |
| Enter | Save the selected setting or go to the next stage |
| + | Scroll up on the menu |
| - | Scroll down on the menu |
| EXIT | Exiting or entering the feature setting mode |

Understanding the Charger Functions

Three-Stage Charging:

The Three-Stage Charging algorithm has a Bulk, then Absorption and then Float sequence. During the Bulk stage, the battery accepts the maximum constant current from the charger. In the Absorption stage, the battery voltage is held to constant voltage and the charging will slowly reduce. In Float stage, the charger continuously produces voltage at a lower level to fully top up the battery and maintain the battery in a fully charged state. The charger will automatically restart the charging cycle in Bulk stage if the battery is discharged to 12.5V. Also, after seven days, the charger will automatically restart the recharging cycle to refresh the battery.

Battery Type:

Three types of battery setting (GEL, AGM and Flooded) are available. See reference battery charging voltage as shown:

| Battery Type | Absorption | Float | Equalization |
|---------------------|-------------------|--------------|---------------------|
| GEL | 14.4 V | 13.8 V | N.A. |
| AGM | 14.3 V | 13.45 V | N.A. |
| Flooded | 14.4 V | 13.5 V | 16.0 V |

Equalize the Flooded Battery:

For Flooded battery type, equalization mode is available. Use the following procedure to equalize the flooded battery. See also section 5 on setting EQ mode for flooded battery.

DANGER: Explosion Hazard. The flooded battery generates explosive gases during equalization. Follow all the battery safety precautions listed in the manual.

CAUTION: Risk of Battery and Equipment damage. Only a Flooded lead-acid battery can

be equalized. Consult your battery manufacturer or read the battery manual when you try to equalize your batteries. Disconnect any DC load connected to the battery, as during equalization mode, the charger will produce 16V to the batteries. You must monitor the battery specific gravity throughout the equalization to determine the end of the equalization cycle.

When EQ mode is set to ON, the unit will charge batteries in one full cycle before it starts to equalize the battery. Check the battery electrolyte level. If necessary, refill with distilled water only. All cells should have similar electrolyte levels. If distilled water is added, batteries must undergo a complete charge cycle. The charger cannot determine when to terminate the equalization of the battery. A 1 hour time-out is intended as a safety feature to terminate the equalizing process. You can re-activate the EQ mode by setting it ON again as necessary after checking batteries manually.

Optional Battery Temperature Sensor Feature:

Optional Battery Temperature Sensor **KISAE Part Number #BTS-10K** is highly recommended to be used with the charger to protect your battery and provide better charging voltage accuracy. The battery temperature sensor senses the battery temperature and makes adjustments to the charging voltage.

| Battery Temperature | Battery Charging Voltage Adjustment from 25 °C normal setting | |
|---------------------|---|---------------|
| | Flooded and GEL type | AGM type |
| < 25 °C | + 0.027 V /°C | + 0.021 V /°C |
| 25 °C | 0 V | 0 V |
| > 25 °C | - 0.027 V /°C | - 0.021 V /°C |

Note: The charger will terminate battery charging when the BTS senses the battery temperature reaching 60 °C. It will not continuously make voltage adjustments when the battery temperature drops to below 0 °C.

Understanding the Error Codes

| Error Code on Display | Condition | Corrective Action |
|-------------------------------------|---|--|
| Fault: E01 Low Battery | Battery voltage is too low and unit has shutdown | Recharge battery immediately and restart unit. |
| Fault: E02 High Battery | Battery voltage is too high and unit has shutdown | Check battery voltage or determine if any external charger with high voltage output is connected to the battery bank |
| Fault: E03 Temp Protect | Internal temperature is too high and unit has shutdown | Check if any object has blocked the air flow of the unit. Check environmental temperature. The unit will restart when the internal temperature has reduced to about 50 °C. |
| Fault: E04 AC Over Load | Inverter AC Output has overload | Check AC load connected and restart the unit. |
| Fault: E05 Short Protect | Inverter output is short circuited and has shutdown | Check load connected to the AC output and restart the unit. |
| Fault: E06 INV Over Load | Inverter output voltage is too high or too low and has shutdown | Check unit and load and restart the unit. |
| Fault: E08 BTS Protect | Battery temperature is high and warning occurs. Unit will shutdown shortly. | Check battery. Check ventilation in battery compartment. Check environmental temperature. |

Estimated Run Times

Following run times are estimates for reference, based on using different battery bank sizes. Actual run times may vary.

| AC Load | Estimate run time on different 12V Battery Bank Size | | | | |
|---------|--|-----------|----------|---------|-----------|
| | 60AH | 120AH | 180AH | 240AH | 300AH |
| 50 W | 11 hrs. | 22 hrs. | 33 hrs. | 44 hrs. | 55 hrs. |
| 100 W | 5 hrs. | 11.5 hrs. | 17 hrs. | 23 hrs. | 29 hrs. |
| 200 W | 2.5 hrs. | 5 hrs. | 8 hrs. | 11 hrs. | 13.5 hrs. |
| 500 W | 49 mins | 2 hrs. | 3 hrs. | 4 hrs. | 5 hrs. |
| 1000 W | 15 mins | 49 mins | 1.5 hrs. | 2 hrs. | 2.5 hrs. |
| 1500 W | 8 mins | 27 mins | 49 mins | 1 hr | 1.5 hrs |
| 2000 W | N.R. | 15 mins | 34 mins | 49 mins | 1 hrs |
| 2500 W | N.R. | 11 mins | 25 mins | 37 mins | 49 mins |
| 3000 W | N.R. | N.R. | 17 mins | 27 mins | 37 mins |

Note: N.R. – Not Recommended

5. FEATURE SETTING

To understand more about the unit features, read the following section and follow the instructions to make changes to the desired setting.

Feature Menu for Unit Setting

To enter feature setting mode, on remote display, press and hold 'EXIT' button for 5 seconds. The feature setting menu will display on the screen with the following sequence:

| Menu Sequence | Setting | Function |
|--|-----------------------|--|
| Charger | On/Off | Turns Battery Charger On/Off |
| Inverter | On/Off | Turns Power Inverter On/Off |
| SCR set | 15, 20,25,30 A | Set AC Input Source Power Breaker Rating. During by-pass mode with high demand for AC power for the load, the charger current is reduced automatically to prevent the tripping of the AC Source power breaker. |
| Power Save | 0, 5, 10, 15, 20, 50W | Lowers power draw when low power loads are connected to inverter |
| Battery Type | AGM, GEL, Flooded | Select battery type |
| Set Current | 60 – 150A (5A step) | Set charger current |
| EQ Mode (Flooded battery type use only) | On/Off | EQ mode is used to equalize the flooded battery. The charging voltage is 16V and the current is set to half the set bulk current for 1 hour (min: 30A, Max: 75A). |
| Fault Alarm | On/Off | Silent mode: Enable or Disable the audible alarm when fault occur |
| Brightness | 10-100% (10% step) | Set LCD Background lighting brightness |
| Backlight Timer | 1–9 mins (1 min step) | Set timer ON for LCD background lighting |

Use the '+' and '-' button to scroll between feature setting menu.

Press 'ENTER' button to go to the selected feature and you can now make changes on the selected feature to your desired setting.

Use the '+' and '-' button to scroll between different set values or setting. Once the desired values or setting is chosen, press 'ENTER' button to save the setting or press 'EXIT' button to quit the setting without saving.

6. TROUBLESHOOTING

To troubleshoot the unit, please note the error code displayed on the main unit and review "Understanding the Error Codes" in section 4.

| Problem | Symptom | Solution |
|--|--|--|
| Condition: Inverter setting is set to Off, AC source is available | | |
| No AC Output. Charging LED is off. | Unit is turned Off | Turn unit ON by following the instruction in Section 4 |
| | AC source is not available | Check AC source. Check AC input branch breaker is off Check AC connection between the AC source and the unit |
| | AC Input breaker is turned off or tripped | Check AC Load and reset AC Input breaker |
| | No DC power to unit Battery voltage is low (<7Vdc) | Check DC fuse, DC Disconnect switch (if installed) and check if Branch breaker is either blown or turned OFF Use a separate charger to boost battery voltage to above 7V and unit can be restarted. |
| No AC output. Fault LED is on | 30A Circuit Breaker is tripped and check fault code | Check load and reset the AC breaker and verify the error condition and make correction. |
| Condition: Inverter setting is set to On, AC source is not available | | |
| No AC Output. Battery Power LED is off | Unit is turned Off | Turn unit ON by following the instruction as in Section 4 |
| | No DC power to unit Battery voltage is low (<7Vdc) | Check DC fuse, DC Disconnect switch (if installed) and check if Branch breaker is either blown or turned OFF Use a separate charger to boost battery voltage to above 7V and unit can be restarted. |
| | AC breaker connected between the Unit AC Output to load is turn off or tripped | Switch on or reset breaker |
| No AC Output. Battery Power LED is on | Check AC Load Sense setting. AC Output power consumption is lower than the AC Load | Decrease AC load sense power level or increase AC load connected to AC Output. |
| | No AC output. Fault LED is on | Check error code |

7. SPECIFICATIONS

Note: Specifications are subject to change without notice.

| Specification | Abso Inverter-Charger 3000 |
|--|--|
| <i>Inverter</i> | |
| AC Output Power | 3000W |
| AC Output Current | 25A |
| AC Surge Power (Peak) | 6000W (5 seconds) |
| AC Output Voltage/Frequency | 120 VAC / 60 Hz |
| AC Output Waveform | True Sinewave (<5% THD) |
| Nominal DC Input Voltage | 12.5 VDC |
| No Load battery draw | < 3.5 A nominal, <1A with load sense |
| DC Input Voltage Operating Range | 11.0 - 16.0 VDC |
| Under Voltage Alarm | 11.8 VDC |
| Under Voltage Alarm Recovery | 12.2 VDC |
| Under Voltage Shutdown | 10.5 VDC |
| Under Voltage Recovery | 11.5 VDC |
| Over Voltage Shutdown | 16.5 VDC |
| <i>AC Transfer Switch</i> | |
| Transfer Time | < 20 ms |
| Transfer Relay Rating | 30A |
| AC Input Source Current Setting (SCR set) | 15, 20, 25A, 30A |
| AC Input L1, N1 | 30A |
| AC Output Line 1 (L1, N1) and Line 2 (L2, N2) | 30A |
| <i>Remote Display</i> | |
| Display Panel Port | RJ45 socket |
| LCD Display | AC Input / Output Voltage & Current DC Input / Output Voltage & Current |
| <i>Battery Temperature Sensor Port</i> | |
| BTS Port | RJ45 socket |
| <i>Charger</i> | |
| Charging Voltage Range | 7.0 – 16.0 VDC |
| Floated Voltage Range | 13.45 – 13.8 VDC |
| Charging Control | 3 Stages (Bulk/Absorption/Float) |
| Charger Current (max) | 150A |
| Charger Current Setting | 60A – 150A |
| Equalization Voltage (Flooded battery setting) | 16.0 VDC |
| Equalization Current (Flooded battery setting) | ½ Bulk Current (min 30A, max 75A) |
| Efficiency | >80% |
| <i>Safety and Environmental</i> | |
| Conformance | Conforms to UL 458 Certified to CSA C22.2 no. 107.1 |
| Agency Markings | cETLus |
| Operating Temperature | 0°C to 40°C (32°F to 104°F) |
| Storage Temperature | -20°C to 60°C (-4°F to 140°F) |
| Relative Humidity | 5-90% noncondensing |
| Operating Altitude | Up to 9,843ft (3000m) above sea level |
| <i>Weights and Dimensions</i> | |
| Weights | 66 lb (30 kg) |
| Dimensions | 15.4 x 13.4 x 7.8" (392x340x197mm) |

8. WARRANTY

One Year Limited Warranty

The limited warranty program is the only one that applies to this unit, and it sets forth all the responsibilities of KISAE. There is no other warranty, other than those described herein. Any implied warranty of merchantability of fitness for a particular purpose on this unit is limited in duration to the duration of this warranty.

This unit is warranted, to the original purchaser only, to be free of defects in materials and workmanship for one year from the date of purchase without additional charge. The warranty does not extend to subsequent purchasers or users.

Manufacturer will not be responsible for any amount of damage in excess of the retail purchase price of the unit under any circumstances. Incidental and consequential damages are specifically excluded from coverage under this warranty.

This unit is not intended for commercial use. This warranty does not apply to damage to units from misuse or incorrect installation/connection. Misuse includes wiring or connecting to improper polarity power sources.

RETURN/REPAIR POLICY:

If you are experiencing any problems with your unit, please contact our customer service department at info@kisaetechnology.com or Phone 1 604 320-7857 before returning product to retail store. After speaking to a customer service representative, if products are deemed non-working or malfunctioning, the product may be returned to the purchasing store within 30 days of original purchase. Any defective unit that is returned to manufacturer within 30 days of the date of purchase will be replaced free of charge.

If such a unit is returned more than 30 days but less than one year from the purchase date, manufacturer will repair the unit or, at its option, replace it, free of charge. If the unit is repaired, new or reconditioned replacement parts may be used, at manufacturer's option. A unit may be replaced with a new or reconditioned unit of the same or comparable design. The repaired or replaced unit will then be warranted under these terms for the remainder of the warranty period. The customer is responsible for the shipping charges on all returned items.

LIMITATIONS:

This warranty does not cover accessories, such as adapters and batteries, damage or defects result from normal wear and tear (including chips, scratches, abrasions, discoloration or fading due to usage or exposure to sunlight), accidents, damage during shipping to our service facility, alterations, unauthorized use or repair, neglect, misuse, abuse, failure to follow instructions for care and maintenance, fire and flood.

If your problem is not covered by his warranty, call our Customer Service Department at info@kisaetechnology.com or 1 604 320-7857 for general information if applicable.