

Energizer[®]

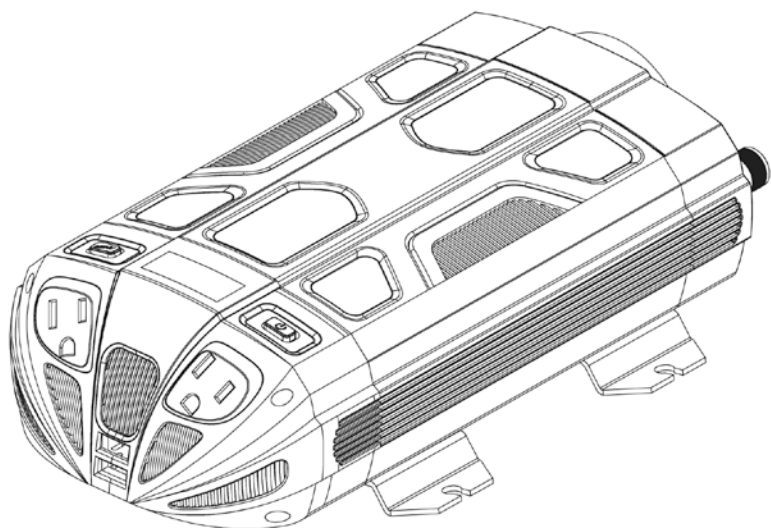

EN900/EN1100 POWER INVERTER

110 VOLT

USER'S MANUAL



E113479
Complies with UL 458
CSA C22.2 No. 107.1

Please read this manual carefully before operation

Toll free: 1 866 295 6775

www.energizerpower.com

© 2012 Energizer Energizer and other marks, including graphics, are trademarks of Energizer and are used under license by Power Bright Technologies.

Printed in China

Welcome

Please read this manual thoroughly before installing and operating your new Energizer® Power Inverter. This manual contains information you need to obtain the performance required for your application. Keep this manual for future reference.

This Energizer® Inverter converts low voltage, direct current (DC) to 110 volt modified sine wave (MSW) alternating current (AC). The inverter draws power from 12 volt, deep-cycle batteries such as those used for marine, golf cart, and fork-lift or from other high current 12 volt sources.

This model, EN900 / EN1100, has been performance tested by MET and complies with Underwriter's Laboratories and Canadian Standards Association safety standards.

A Higher Wattage Inverter May Be Required

To determine whether the Energizer® EN900 / EN1100 will operate a particular appliance or a combination of appliances, run a test. All inverters are designed to automatically shut down in the event of a power overload. This protection feature prevents damage to the unit while testing appliances with combined wattages in the 900 / 1100 watt range. Turn on the highest wattage appliance first then other appliances. If an appliance combination in the 900 / 1100 watt range will not operate properly, then it is likely that this Energizer® inverter does not have the required capacity to operate the appliance in question.

WARNINGS, CAUTIONS AND NOTES

It is very important that any operator and installer of this inverter read and follow all **WARNINGS, CAUTIONS AND NOTES** and all installation and operation instructions. In particular, comply with **WARNINGS** (possibility of serious injury or death), **CAUTIONS** (possibility of damage to the inverter and / or other equipment), and **NOTES** (included to assist you in achieving the maximum performance and longest working life from this advanced-design inverter).

WARNINGS: INVERTER OUTPUT

This is a heavy-duty device that produces voltages similar to commercial AC power.

- Danger of shock or electrocution - treat inverter output the same as commercial AC power.
- Do not use the inverter near flammable materials or in any locations that may accumulate flammable fumes or gases. This is an electrical device that can briefly spark when electrical connections are made or broken.
- Do not allow water or other liquids to contact the inverter.
- Do not use appliances with damaged or wet cords.

CAUTIONS: INVERTER OPERATING ENVIRONMENT

- Surrounding air temperature should be between -20°C and 40°C – ideally between 15°C and 25°C (60 - 80°F).
- Keep the inverter away from direct sunlight if at all possible.
- Keep the area surrounding the inverter clear to ensure free air circulation around the unit. Do not place items on or over the inverter during operation. The unit will shut down if the internal temperature gets too hot. Restart the inverter after it cools.
- This Energizer® inverter will only operate from a 12V power source. Do not attempt to connect the inverter to any other power source, including any AC power source.
- Do not reverse DC input polarity – this will void the warranty.

APPLIANCE CAUTIONS

- Do NOT plug in battery chargers for cordless power tools if the charger carries a warning that dangerous voltages are present at the battery terminals.
- Certain chargers for small nickel-cadmium or nickel-metal-hydride batteries can be damaged if powered by this inverter. Two types of appliances are susceptible to damage: Small, battery-operated appliances such as flashlights, cordless razors and toothbrushes that plug directly into an AC receptacle.
- Do NOT use this inverter with the above two types of equipment.
- The majority of portable appliances do not have this problem. Most portable appliances use separate transformers or chargers that plug into AC receptacles to supply a low-voltage DC or AC output to the

appliance. If the appliance label states that the charger or adapter produces a low-voltage DC or AC output (30 volts or less), there will be no problem powering that charger or adapter.

- Some fans with synchronous motors may slightly increase in speed (RPM) when powered by the inverter. This is not harmful to the fan or to the inverter.
- Route appliance cords and extension cords to prevent accidental pinching, crushing, abrading and tripping people.
- Use safety approved extension cords rated at 15 amps or higher.
- GFCI devices may not work with modified sine wave (MSW) power.
- This inverter is not tested for use with medical equipment.
- This inverter is not tested for use in marine applications.
- In the event of a continuous audible alarm or automatic shut down, turn the inverter OFF immediately. Do not restart the inverter until the source of the problem has been identified and corrected.
- When attempting to power lead acid battery chargers, with modified sine wave, monitor the temperature of the battery charger for approximately 10 minutes. If the battery charger becomes abnormally warm, immediately disconnect it from the inverter.

Getting Started

When a motorized appliance or a tool turns on, there is an initial surge of power to start. This surge of power is referred to as the "starting load" or "peak load." Once started, the tool or appliance requires less power to operate. This is referred to as the "continuous load" in terms of power requirements. You will need to determine how much power your tool or appliance requires to start up (starting load) and its continued running power requirements (continuous load).

Power consumption is rated in watts, or it can be calculated from amperes (amps). This information is usually stamped or printed on most appliances and equipment. If this information is not indicated on the appliance or equipment, check the owner's manual. For electrically sensitive equipment, contact the manufacturer to determine if the device you are using is compatible with modified sine wave AC.

Multiply: **AC AMPS X 110** (AC voltage) = **WATTS**

This formula yields a close approximation of the continuous load of your appliance.

Multiply: **WATTS X 2** = Starting Load for most appliances

This formula yields a close approximation of the starting load of most appliances. Exceptions are motorized appliances such as pumps, freezers and air conditioners. These appliances can have startup loads of up to eight times the rated watts.

Front Panel EN900 / EN1100

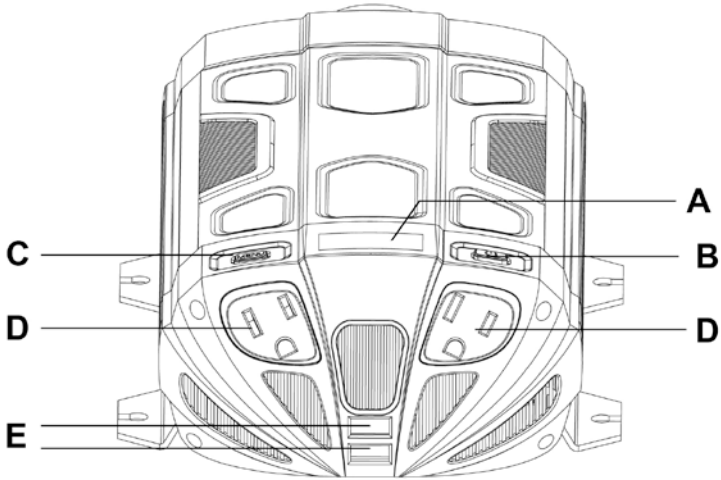

- A. LCD Digital Display (See LCD Diagram Below).
- B. ON / OFF Switch. Turns the inverter circuits ON and OFF.
- C. Display Selector Switch.
- D. Two standard North American AC outlets, each rated at 15 Amps (1650 Watts).
- E. Two USB Ports (2.1 Amp Shared).

LCD Diagram

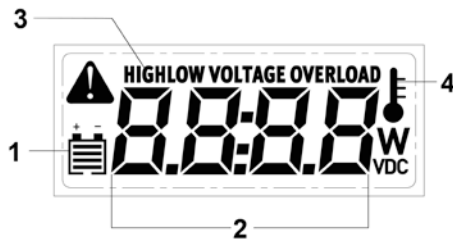

- 1. Battery Level.
- 2. Output wattage (W) or input voltage display (VDC).
- 3. Warning indicator –
 - a. High voltage
 - b. Low voltage
 - c. Voltage overload.
- 4. Temperature shutdown.

Rear Panel EN900 / EN1100

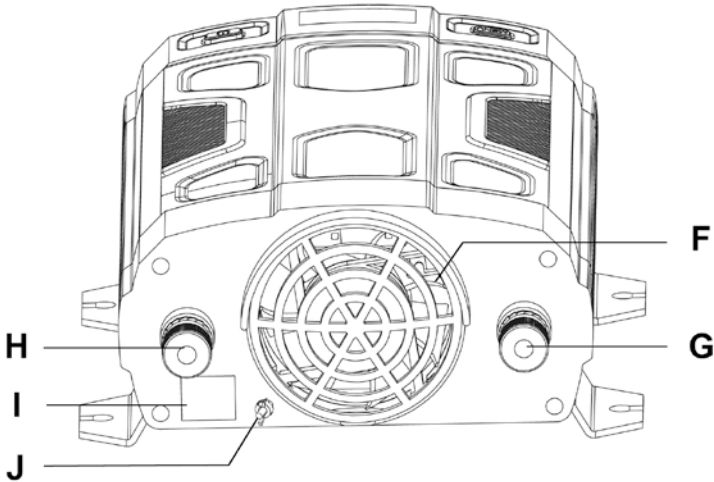

- F. High-Speed Cooling Fan. When the temperature inside the inverter exceeds a preset limit, the Cooling Fan automatically turns on to cool the inverter. When the temperature reduces, the fan turns off.
- G. Negative Power Input Terminal.
- H. Positive Power Input Terminal.
- I. Remote Control Receptacle.
- J. Ground Terminal.

Determining the DC Power Requirements

Powering multiple appliances from the high-power EN900 / EN1100 inverter requires a 12 volt bank of batteries (several batteries). To calculate the approximate power in amps a 12 volt battery bank has to supply you need to know the current, or amps required for powering the continuous AC load.

A shortcut method is to divide the continuous AC load wattage by 10. For example, the continuous AC load is 900 watts. The current (amps) is: $900/10$ or 90 amps at 12 VDC. Add to the load any DC appliances that may be powered by the battery bank.

Sizing the Battery Bank

To determine the minimum battery bank ampere-hour rating that you will need to operate appliances from the inverter, and any DC appliances powered by the battery bank, follow these steps:

1. List the maximum wattage that the inverter has to provide (as above).
2. Estimate the number of hours the appliances will be in use between battery recharges. This will differ depending on appliances. As an example, a typical home-use coffeemaker draws 500 watts during its brew time of 5 minutes; it maintains the temperature of the pot at about 100 watts. Typical use of a microwave oven is only for a few minutes. Some longer operating time appliances are lamps, TVs, computers and refrigerator / freezers.
3. Determine the total watt-hours of energy needed. Then multiply the average power consumption in watts by the number of hours of run time. For example: 900 watts for 10 hours = 9,000 watt hours. Using the 900 watts (or 90 Amps) for 10 hours example as above, then 90 amps is needed for 10 hours. This provides us with the basic amp-hours (AH) of battery that is required. Ten hours at 90 amps equals 900 Amp Hours (AH). This answer is just a beginning because there are other conditions that determine actual run time. These include:
 - AC appliance load and time in use (basic Amp Hour)
 - Cable gauge and length (cable losses)
 - Charge level of the batteries (between use, chargers have to be able to fully charge the batteries)
 - Temperature of the batteries (colder batteries provide fewer amps)
 - Age and condition of the batteries (older batteries lose capacity/amp hours)
 - Compliance with turning off unnecessary AC and DC loads.

If there is any doubt about sizing the battery bank, it is safe to over estimate the amp hour requirements of the battery bank.

Note:

The type of batteries you use to power your high power inverter is important. Operating a high-power inverter will routinely discharge batteries and they will require frequent recharging. Batteries used to start engines are not designed to repeatedly charge and discharge. Energizer® recommends using “deep-cycle” or “marine” rated batteries.

Cable Gauges

When connecting the inverter to a battery bank use the thickest stranded insulated copper wire available, in the shortest length practical. Recommended cable gauges are as follows:

Energizer® Model #	Recommended Gauges
EN500	12AWG (3 ft. included)
EN900	8AWG (3 ft. included)
EN1100	8AWG (3 ft. included)
EN1500	4AWG (not included)
EN2000	2AWG (not included)
EN3000	0AWG (not included)
EN4000	0AWG (not included)

WARNING:

DANGER OF BATTERY EXPLOSION – INSTALL A FUSE

Battery banks can deliver very high levels of current that can vaporize metal, start fires and cause explosions. Energizer® recommends installing one ANL type fuse and fuse holder close to the positive battery bank terminal. This fuse protects the batteries from accidental DC cable shorts, which can cause batteries to explode. ANL fuses and fuse holders are available at most marine supply stores.

CAUTIONS:

- Loose connections can result in a severe decrease in voltage that can cause damage to cables and insulation.
- Failure to make correct polarity (Pos, Neg) connection between the inverter and the battery bank can result in blowing fuses in the inverter and can permanently damage the inverter. Damage caused by reversed polarity is not covered under the Energizer® warranty.

- Making the connection to the Positive terminal may cause a spark as a result of current flowing to charge capacitors within the inverter. This is a normal occurrence.
- Because of the possibility of sparking, however, it is extremely important that both the inverter and the 12 volt battery be positioned far from any possible source of flammable fumes or gases. Failure to heed this warning could result in fire or explosion.
- Operating the inverter without correctly grounding the unit may result in electrical shock.

Mounting the Inverter

Your Energizer® Inverter should not be mounted under the hood of a vehicle.

If installing in a vehicle, choose a dry, cool, ventilated area closest to the battery as practical. Before drilling any mounting holes, make sure that there are no wires, fuel lines, or tanks directly behind the surface to be drilled. To mount the inverter:

1. Inverter must be OFF.
2. The inverter should be mounted horizontally.
3. Position the inverter against the mounting surface and mark locations of the mounting screw openings.
4. Remove the inverter and drill four mounting holes.
5. Fasten the inverter to the mounting surface using corrosion-resistant fasteners sized #10 or larger.

Connecting the Inverter

This inverter has two DC cable connections, one positive and one negative. The order of steps in the following procedure minimizes the danger of sparking near the battery bank.

1. Prepare all cable set ends with ring terminals at the battery ends.
2. Install one fuse holder with fuse in the Pos cable close to the battery bank end.
3. Make sure the inverter is OFF.
4. Ensure all appliance cords or extension cords are disconnected from the inverter.
5. Connect an appropriate stranded insulated wire to the enclosure ground terminal and connect the free end of the wire to the vehicle's

chassis or any other ground point.

6. Connect the un-fused cable to the Negative (-) terminal of the battery bank.
7. Connect the Negative cable to the Inverter's Negative (-) terminal.
8. Insulate the end of cable to be connected to the Pos (+) Inverter terminal.
9. Connect the fused cable to the battery bank Pos (+) terminal.
10. Connect the Pos cable end to the Pos (+) inverter terminal.

NOTE: Sparking is normal for the first connection.

Make sure you have good secure connections – Do not over-tighten.

Operation

1. Turn On the inverter.
2. Turn OFF the inverter.
3. When you have confirmed that the appliance to be operated is turned off, plug an appliance cord into one of the two 110v AC Outlets on the front panel of the inverter.
4. Turn ON the inverter.
5. Turn the appliance on.
6. Plug in additional appliances and turn them on.

Note:

The audible alarm may make a momentary "chirp" when the inverter is turned OFF. This same alarm may also sound when the inverter is being connected to or disconnected from the 12 volt battery bank.

Television and Audio Suggestions

Although all Energizer[®] inverters are shielded and filtered to minimize signal interference, some interference with your television picture may be unavoidable, especially in weak signal areas.

However, here are some suggestions that may improve reception:

1. First, make sure that the television antenna produces a clear signal under normal operating conditions. Also, ensure that the antenna cable is properly shielded and of good quality.
2. Change the positions of the inverter, antenna cables and TV power cord.
3. Isolate the TV, its power cord and antenna cables from the 12 volt

power source by running an extension cord from the inverter to the television set.

4. Coil the television power cord and the input cables running from the 12 volt power source to the inverter.
5. Attach a "Ferrite Data Line Filter" to the television power cord. More than one filter may be required. These filters are available at most electronic supply stores.

Note:

Some inexpensive audio systems may produce a slight "buzzing" sound when operated with the inverter. The only solution to this problem is to use a sound system with better power supply filtering.

Operating a Microwave oven with Your Power Inverter

The power rating used with microwave ovens is the "cooking power" which means the power being "delivered" to the food being cooked. The actual operating power rating is listed on the back of the microwave. If the operating power cannot be found on the back of the microwave, check the owner's manual or contact the manufacturer.

How This Modified Sine Wave Power Inverter Works

There are two stages in which this power inverter changes the 12 volt DC (or battery) power into 110v AC (household current).

STAGE 1: This inverter uses a DC to DC converter to increase the DC input voltage from the battery to 145 volts DC.

STAGE 2: The inverter then converts the high voltage DC into 110v AC (household current), using advanced MOSFET transistor in a full bridge configuration. This design provides this Energizer® inverter with the capability to start and run difficult reactive loads, while providing excellent overload capability. The waveform that is generated by this conversion is a "modified sine wave" as shown in the diagram below.

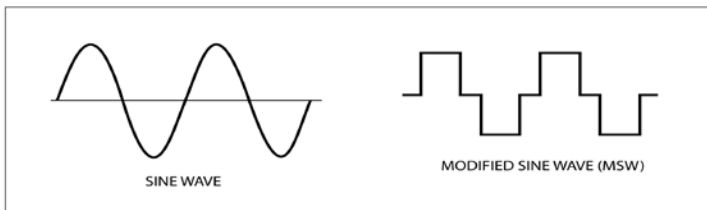

Best use of Battery Power

Make sure any appliances are energy efficient and turned off after use. Use Compact Florescent Lamps. Wherever possible, charge with Solar Panels or Wind Generators. Do not allow lead acid batteries to remain discharged for long periods of time, they lose capacity (amp hours).

Disposal / Recycling of Inverter / California Proposition 65

Electronic products are known to contain materials that are toxic if improperly disposed. Contact local authorities for disposal and recycling information.

This inverter is certified to be "lead free." Transformers in this inverter contain nickel composites. Nickel is a known neuro-toxin if ingested.

Troubleshooting

PROBLEM: No Input Voltage

Reason	Solution
Poor contact with battery terminals.	Shut down inverter and disconnect. Clean terminals thoroughly and reconnect.
Blown DC battery fuse(s).	Turn off inverter. Fix problem. Replace fuse(s) with same type and rating.

PROBLEM: Inverter is Shut Down

Reason	Solution
Battery voltage below 10 Volts.	Charge or replace battery.
Inverter is too hot (thermal shut down mode). Will be indicated on LCD panel.	Allow inverter to cool. Check for adequate ventilation. Reduce the load on the inverter to rated continuous power.
Unit may be defective.	See warranty and call customer service.

PROBLEM: Low Battery Alarm on all the Time

Reason	Solution
Input voltage below 10.5 Volts. Will be indicated on LCD panel.	Keep input voltage above 10.5 Volts to maintain regulation.
Poor or weak battery condition.	Recharge or replace battery.
Inadequate power being delivered to the inverter or excessive voltage drop.	Use lower gauge (heavier) cable. Keep cable length as short as possible.

PROBLEM: TV does not Work

Reason	Solution
TV does not turn on.	Contact TV manufacturer to find out if the TV is compatible with a modified sine wave.

Specifications: EN900

Specifications	Description
Output Continuous Watts (W)	900 W +10W (USB)
Surge Capacity (Peak Power)	1800 W
Rated Input DC (V,A)	12VDC , 85A
Input Voltage Range	10.5 to 15.5 VDC
Rated Frequency (Hz)	(60Hz±1)
Rated Output AC (V,A)	6.7A(105-125)
Rates Output USB (V,A)	2 * 5V/max. 2.1A (I-Pad)
No Load Current	<0.3A DC
Optimum Efficiency	90% min.
Fuse (A)	35A*3
Fuse Type	Internal Blade
Output Wave Form	Modified Sine Wave
Max. Touch Temperature	65°C Max
Operating Temperature	0° to 40°C
Operating/Storage Humidity RH	5 to 95%
Cooling System	Thermo Fan
THD	35%
Power Factor	0.65 Min
Ripple & Noise(Peak to Peak)	<250mV
Dimensions LxWxH (inches)	10.28 x 5.59 x 2.72
Assembled Weight (LBS)	2.58 lbs.

NOTE:

All specifications are typical at nominal line, half load, and 77°F (25°C) unless otherwise noted. Specifications are subject to change without notice.

Specifications: EN1100

Specifications	Description
Output Continuous Watts (W)	1100 W +10W (USB)
Surge Capacity (Peak Power)	2200 W
Rated Input DC (V,A)	12VDC , 118A
Input Voltage Range	10.5 to 15.5 VDC
Rated Frequency (Hz)	(60Hz±1)
Rated Output AC (V,A)	, 12.5A(105-125)
Rates Output USB (V,A)	2 * 5V/max. 2.1A (I-Pad)
No Load Current	<0.5A DC
Optimum Efficiency	90% min.
Fuse (A)	(40A*3)
Fuse Type	Internal Blade
Output Wave Form	Modified Sine Wave
Max. Touch Temperature	65°C Max
Operating Temperature	0° to 40°C
Operating/Storage Humidity RH	5 to 95%
Cooling System	Thermo Fan
THD	35%
Power Factor	0.65 Min
Ripple & Noise(Peak to Peak)	<250mV
Dimensions LxWxH (inches)	10.98 x 5.59 x 2.72
Assembled Weight (LBS)	3.16 lbs.

NOTE:

All specifications are typical at nominal line, half load, and 77°F (25°C) unless otherwise noted. Specifications are subject to change without notice.

Warranty and Return

Warranty by PowerBright

What does this warranty cover? This Limited Warranty is provided by PowerBright and covers defects in workmanship and materials in your EN900 / EN1100. This warranty period lasts for 12 months from the date of purchase at the point of sale to you, the original end user customer. Proof of purchase is required to make warranty claims.

What will PowerBright do? PowerBright will, at its option, repair or replace the defective product free of charge, provided that you notify PowerBright of the product defect within the Warranty Period, and provided that PowerBright, through inspection, establishes the existence of such a defect and that it is covered by this Limited Warranty. PowerBright will, at its option, use new and / or reconditioned parts in performing warranty repair and building replacement products. PowerBright reserves the right to use parts or products of original or improved design in the repair or replacement. If PowerBright repairs or replaces a product, its warranty continues for the remaining portion of the original Warranty Period or 90 days from the date of the return shipment to the customer, whichever is greater. All replaced products and all parts removed from repaired products become the property of PowerBright. PowerBright covers both parts and labor necessary to repair the product, and return shipment to the customer via a PowerBright selected non-expedited surface freight within the contiguous United States and Canada. Alaska and Hawaii are excluded. Contact PowerBright Customer Service for details on freight policy for return shipments outside of the contiguous United States and Canada.

How do you get service? If your product requires troubleshooting or warranty service, contact your dealer. If you are unable to contact your dealer, or the dealer is unable to provide service, contact PowerBright directly at:

Toll Free: 1 866.295.6775

Website: www.PowerBright.com

Direct returns may be performed according to the PowerBright Return Material Authorization Policy described in your product manual. For some products, PowerBright maintains a network of regional Authorized Service Centers. Call PowerBright or check our website to see if your product can be repaired at one of these facilities.

What does this warranty not cover? This Limited Warranty does not cover normal wear and tear of the product or costs related to the removal, installation, or troubleshooting of the customer's electrical systems. This warranty does not apply to, and PowerBright will not be responsible for, any defect in or damage to:

1. the product if it has been misused, neglected, improperly installed, physically damaged or altered, either internally or externally, or damaged from improper use or use in an unsuitable environment;
2. the product if it has been subjected to fire, water, generalized corrosion, biological infestations, or input voltage that creates operating conditions beyond the maximum or minimum limits listed in the PowerBright product specifications including high input voltage from generators and lightning strikes;
3. the product if repairs have been done to it other than by PowerBright or its authorized service centers (hereafter "ASCs");
4. the product if it is used as a component part of a product expressly warranted by another manufacturer;
5. the product if its original identification (trade-mark, serial number) markings have been defaced, altered, or removed.

Exclusions

If this product is a consumer product, federal law does not allow an exclusion of implied warranties. To the extent you are entitled to implied warranties under federal law, to the extent permitted by applicable law they are limited to the duration of this Limited Warranty. Some states and provinces do not allow limitations or exclusions on implied warranties or on the duration of an implied warranty or on the limitation or exclusion of incidental or consequential damages, so the above limitation(s) or exclusion(s) may not apply to you. This Limited Warranty gives you specific legal rights. You may have other rights which may vary from state to state or province to province.

Warning: Limitations On Use

Please refer to your product manual for limitations on uses of the product. SPECIFICALLY, PLEASE NOTE THAT THE EN900 / EN1100 SHOULD NOT BE USED IN CONNECTION WITH LIFE SUPPORT SYSTEMS OR OTHER MEDICAL EQUIPMENT OR DEVICES.

WITHOUT LIMITING THE GENERALITY OF THE FOREGOING, POWERBRIGHT MAKES NO REPRESENTATIONS OR WARRANTIES REGARDING THE USE OF THE ENERGIZER EN900 / EN1100 IN CONNECTION WITH LIFE SUPPORT SYSTEMS OR OTHER MEDICAL EQUIPMENT OR DEVICES.

Return Material Authorization Policy

Before returning a product directly to PowerBright you must obtain a Return Material Authorization (RMA) number and the correct factory "Ship To" address. Products must also be shipped prepaid. Product shipments will be refused and returned at your expense if they are unauthorized, returned without an RMA number clearly marked on the outside of the shipping box, if they are shipped collect, or if they are shipped to the wrong location.

When you contact PowerBright to obtain service, please have your instruction manual ready for reference and be prepared to supply:

- The serial number of your product
- Information about the installation and use of the unit
- Information about the failure and / or reason for the return
- A copy of your dated proof of purchase.

Return Procedure

1. Package the unit safely, preferably using the original box and packing materials. Please ensure that your product is shipped fully insured in the original packaging or equivalent. This warranty will not apply where the product is damaged due to improper packaging.
2. Include the following:
 - The RMA number supplied by PowerBright Technology, Inc. clearly marked on the outside of the box.
 - A return address where the unit can be shipped. Post Office Boxes are not acceptable.
 - A contact telephone number where you can be reached during work hours.
 - A brief description of the problem.
3. Ship the unit prepaid to the address provided by your PowerBright customer service representative.

If you are returning a product from outside of the USA or Canada In addition to the above, you **MUST** include return freight funds and are fully responsible for all documents, duties, tariffs, and deposits.

